

- Flexible, compact and economic design
- High degree of freedom (one-arm/ double-arm system) to address all alignment requirements
- Operator friendly and intuitive usage
- Manually guided and/or motorized control
- Modular configuration and customized cable management for individual test-floor applications
- Robust design and high quality manufacturing

Weight Capacity up to ~750 kg / 1650 lbs

# Manipulator Overview



Download  
Flyer!



Watch  
Video!

# Tiger Series Motorized Manipulators

## Tiger M 250U

TD1350 L/R

for medium Test Heads  
up to **~250 kg/550 lbs.**

Similar to Trolley version, but with  
linear footing and rotational column

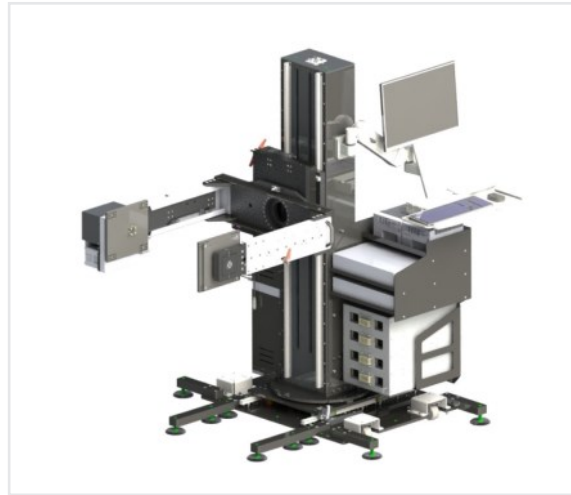

## Tiger M 350U | 450U

TD1360\_70 L/R

for medium Test Heads  
up to **~350 | 450kg / 770 | 992 lbs.**

Similar to Trolley version, but with  
linear footing and rotational column



## Tiger M 750U

TD1380 R

for heavy Test Heads  
up to **~750kg / 1650 lbs.**

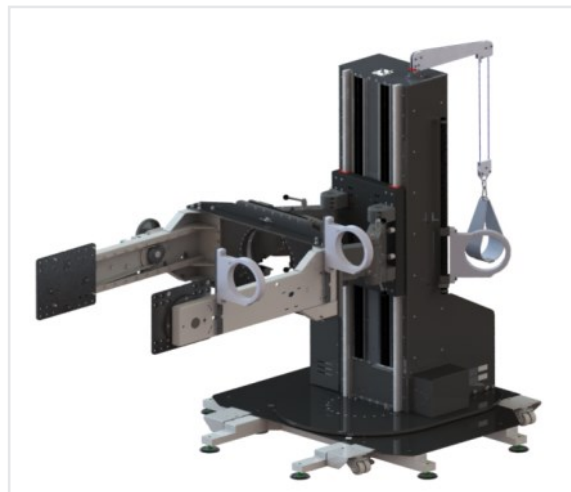

# Counterbalance Manipulators



## **TDM 10**

for light Test Heads  
up to ~120 kg / 265 lbs.



## **TDM 20**

for medium Test Heads  
up to ~300 kg / 660 lbs.



## **TD 2060/80**

for heavy Test Heads  
up to ~450 kg / 992 lbs.

# Tiger H 350/700 Hinge Manipulators



## Load carrying capability

- Tiger H 350: up to 350 kg / 772 lbs.
- Tiger H 700: up to 700 kg / 1543 lbs.

**Modular, scalable architecture** for different customer and application requirements.

## Scaling configurations:

1. **Cost optimized** with swing motion
2. **Pogo stack protection** with swing & vertical motion



## Features & Options:

- **Best setup and docking repeatability** with the Hinge architecture
- **Excellent pogo stack protection** by additional final pure vertical travel and contact engagement, reducing pogo stack ware and maintenance cost.
- **Prevention of the overdrive and safety hazards**
  - ◆ Redundant dock position sensing concept
  - ◆ Slow motion with **two hand operation**
- **Twist-/Tumble-turn** (optional)
- **Footprint saving footing options**, adapted to the final applications (prober types / rear or side docking)
- **Stand-alone or direct-mount** to prober
- **Touch screen controlled HMI**
- **Fully automated**
  - ◆ **work flows**
  - ◆ **total solution** with various Turbodynamics' docking solutions



## Smart Factory Testcell Integrator

Turbodynamics is offering besides testhead manipulators a whole portfolio to support testcell integration with trolleys, docking interfaces for all test heads, test handlers and probers. We are well known for innovative customized docking and probe card handling solutions. Turbodynamics is technology and market leader in probe card auto-exchange, handling and storage to support smart factory / Industry 4.0 requirements.

For more information contact us at:

### Turbodynamics GmbH

Neue Strasse 9 | 83071 Stephanskirchen | Germany

Email: [info@turbodynamics.com](mailto:info@turbodynamics.com) | Phone: +49 8031 90194-0 | Fax: +49 8031 90194-129