



Weight Capacity up to 450 kg / 992 lbs

- Mobile Test Head Trolley enables shifting of test heads between test cells
- Smallest footprint due to innovation w/o counterweight
- Ergonomic and high degree of freedom to adress all alignment requirements
- Operator friendly and intuitive usage
- Manually guided and/or motorized control
- Modular configuration for individual testfloor applications
- Robust design and high quality manufacturing

# Tiger Trolley Series Overview



# Final Test Trolleys



## **Tiger T 150F TD1255**

for light Test Heads  
up to ~150 kg / 330 lbs.



## **Tiger T 350F TD1275**

for medium Test Heads  
up to ~350 kg / 770 lbs.



## **Tiger T 450F TD1285**

for heavy Test Heads  
up to ~450 kg / 992 lbs.

# Universal Trolleys

## **Tiger T 250U TD1350**

for medium Test Heads  
up to ~250 kg / 550 lbs.



## **Tiger T 350U TD1360**

for medium Test Heads  
up to ~350kg / 770 lbs.



## **Tiger T 450U TD1370**

for heavy Test Heads  
up to ~450kg / 992 lbs.



# Tiger Test Head Trolleys

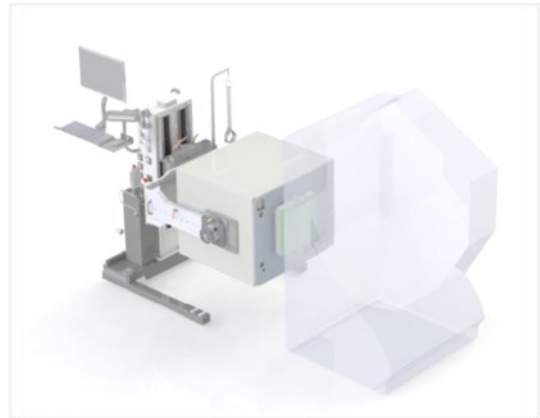
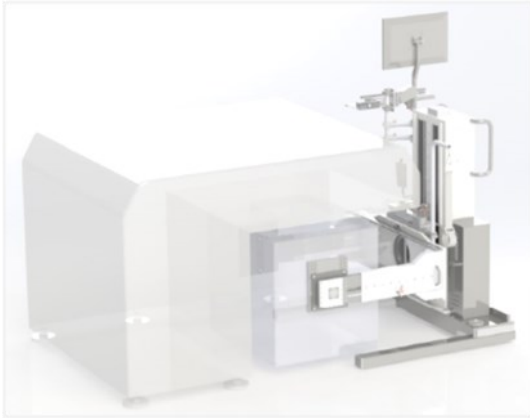

**Final Test applications for horizontal and vertical IC Test-Handler**

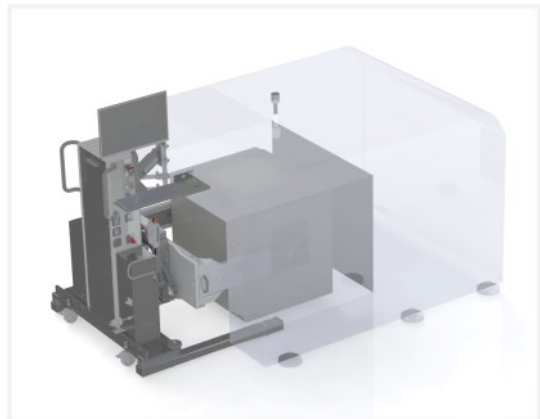

**Universal Solutions for Final Test and Probing applications**

## Smart Factory Testcell Integrator

Turbodynamics is offering besides testhead trolleys a whole portfolio to support testcell integration with manipulators, docking interfaces for all test heads, test handlers and probers. We are well known for innovative customized docking and probe card handling solutions. Turbodynamics is technology and market leader in probe card auto-exchange, handling and storage to support smart factory / Industry 4.0 requirements.

For more information contact us at:

**Turbodynamics GmbH**

Neue Strasse 9 | 83071 Stephanskirchen | Germany

Email: [info@turbodynamics.com](mailto:info@turbodynamics.com) | Phone: +49 8031 90194-0 | Fax: +49 8031 90194-129